

P/N: QD-60

Micro-Computer Remote Control For A/C

Universal Replacement with 5 Working Modes, 3 Fan Speed, AC 100V~240V.

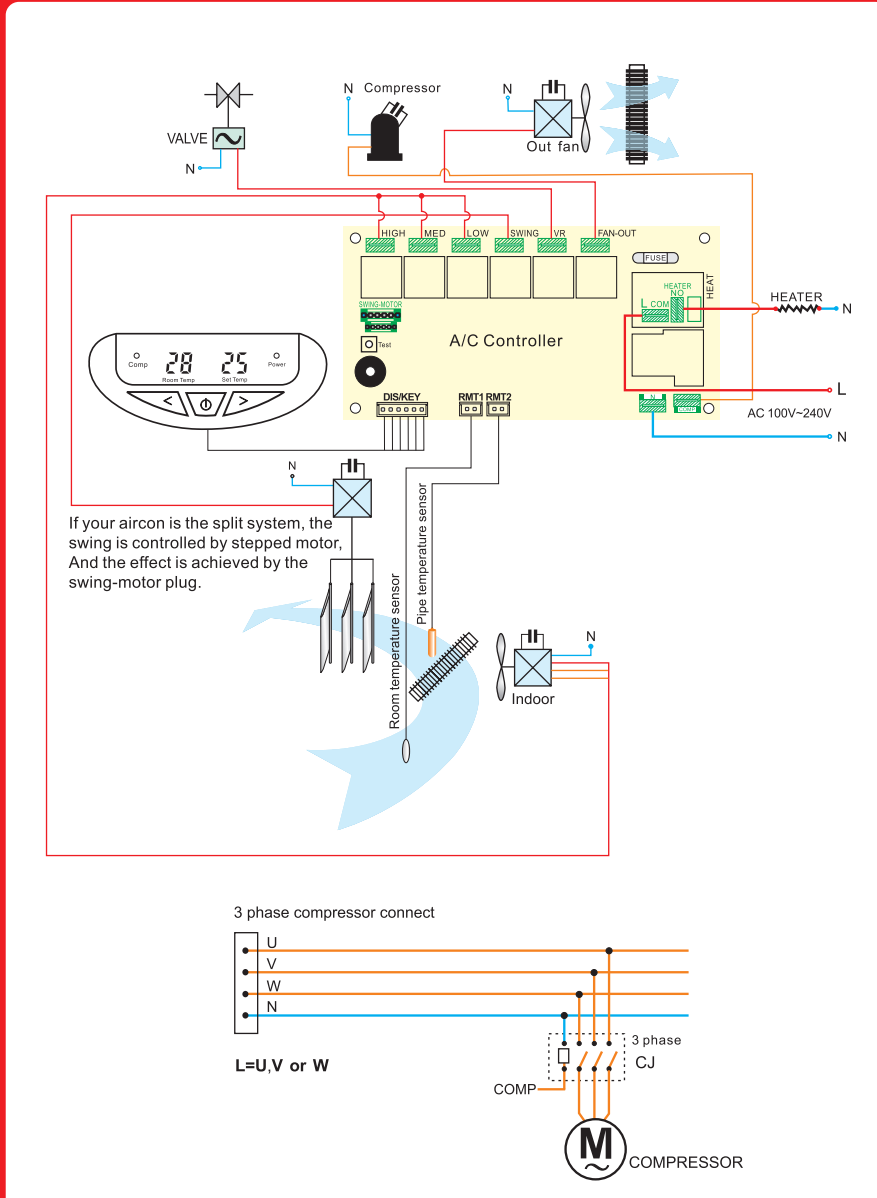

This product does not apply inverter A.C

Notice:

- 1.- When the compressor is shut off, it needs 3 minutes to restart.
- 2.- Make sure there is no strong light in front of the IR receiver.
- 3.- Please send for the technician for the installation. Ensure to conduct the electrical test before the installation. Any damage caused by the incorrect installation shall not be guaranteed. After installation, test the control system. Remember to avoid strong light in front of the receiver to avoid interference in the testing process.