

Preface

MCRC-002 is our latest universal control system for DC inverter split air conditioners. Thank you for choosing this product, and it's our great pleasure to bring convenience for your daily life. Please read the user's manual carefully before using this control system, which will assist you to install and use the control system correctly.

Control System Introduction

- 1) Parts of control system: ① universal indoor board, ② remote control, ③ universal outdoor inverter board, ④ electrolytic capacitor board.
- 2) Enable to drive strong DC compressor.
- 3) Enable to drive indoor DC fan motor.
- 4) Enable to drive outdoor DC/AC fan motor.
- 5) Applicable for controlling electronic expansion valve.

⚠️ Attentions Before Installation

It is not applicable for AC indoor fan motor. If needs, indoor units should be replaced with Everwell other models.

- Please hire technicians with qualification for installation and do conduct power-on test before it. There is still high voltage in the PCBA board within 3 minutes after power off. Please be careful.
- Please identify the air conditioner type(DC inverter or AC inverter) and the fan motor type(DC fan motor or AC fan motor).
- Users just need to use the gear 1 to select DC inverter or AC inverter. Ensure other gears remain default setting.
- Gear 1 (default setting is at the number side) is suitable for DC compressor. So before installation, please identify the compressor type(DC inverter or AC inverter). For AC inverter, please set gear 1 to be ON side.
- Ensure the electrolytic capacitor positive/negative pole connect to the ⊕ and ⊖ plug of the module correctly.
- Connect the three wires(U, V, W) of the original compressor with plugs (U, V, W) of the outdoor inverter board correspondingly. Ensure the connection is stable.
- with 3 minutes' delay for protection, the compressor will restart after 3 minutes for power off or defrost.
- If the air conditioner works absolutely nosily, check three phases to see if there are cases of phase missing or phase dislocation. Ensure the maximum compressor working current is less than 110% of air conditioner rated current.
- Any damage due to improper installation or burned module from human factors are not in warranty scope. If products need factory maintenance, please return the main board together with the packing box and a note to clarify specific failure phenomenon.

Outdoor unit instruction
A. Structure and Installation of Outdoor Inverter Board

- 1) Outdoor inverter board structure diagram
- ① Exhaust temperature sensor connection port: when compressor exhaust temperature is higher than 110°C, it will shut down for protection.
- ② Dial switch: it has 4 gears to choose. Users just need to use gear 1 to select DC inverter or AC inverter. Ensure other gears remain the default setting. The default setting(at the number side) for gear 1 is suitable for DC compressor. So before installation, please identify the compressor type(DC inverter or AC inverter). For AC inverter, please set gear 1 to be ON side.
- ③ Indicator light: when the unit is working normally, choosing DC inverter, the green LED light will be on; Choosing AC inverter, the green LED light will flicker. When failures occur, the green LED light will be off, and the red LED light will flicker. The red LED light will flicker differently according to the failure phenomenon. For details, please check the Failure Guide for reference.
- ④ Electronic expansion valve connection port: electronic expansion valve has two types of wires: 5 wires and 6 wires,

- please find the 12V terminal through referring to the connection way of original inverter board and expansion valve.
- ⑤ N TERMINAL: Null line input.
- ⑥ COMP TERMINAL: connect with the COMP of the universal indoor board.
- ⑦ ⊖ TERMINAL: connect with the negative pole of electrolytic capacitor board.
- ⑧ Outdoor DC fan motor connection port: when connecting the DC fan motor, please ensure the corresponding connection between DC fan motor and inverter board. If the outdoor fan motor is AC, then you need to use the indoor board to control it.
- ⑨ U, V, W output terminal: connect with the wires(U, V, W) of compressor correspondingly. If reverse rotation occur, please exchange two wires of them.
- ⑩ ⊕ TERMINAL: connect with the positive pole of electrolytic capacitor board.
- ⑫ Fixed pole for radiator: stabilize the outdoor inverter board on the heat sink of the original unit.

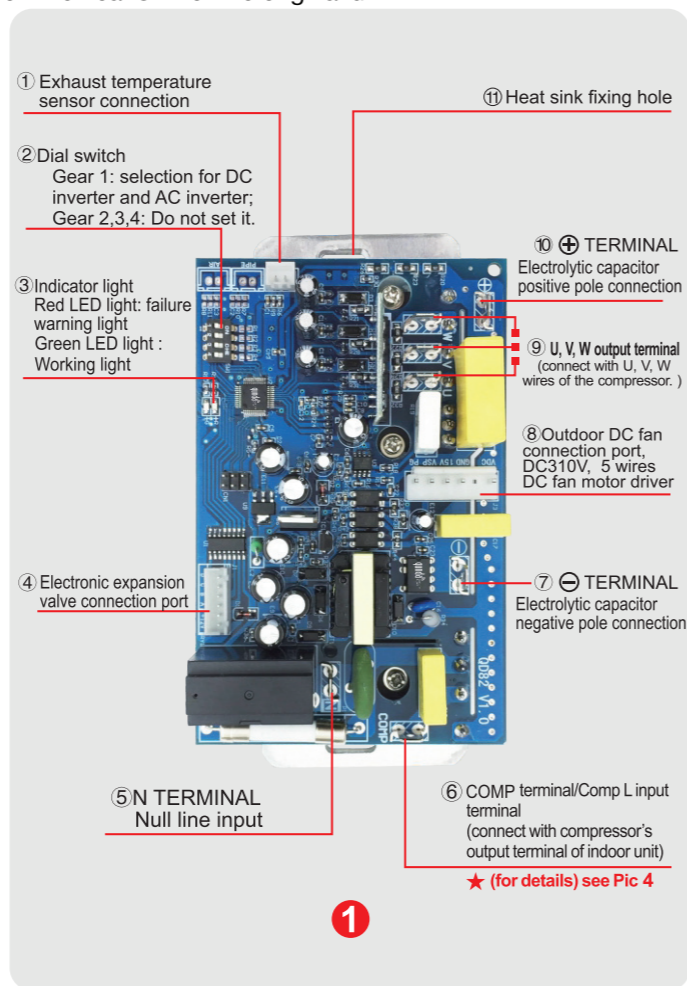

Gear	ON	NUMBER (1,2,3,4)
1	AC INVERTER	DC INVERTER
2	NULL	NULL
3	NULL	NULL
4	NULL	NULL

2) Installation for outdoor inverter board:

Step 1: Before installation, please use the ohm band of the multimeter to test the compressor and make sure the compressor coil is good and the resistance of three compressor feet is the same. If not, something may be wrong with the compressor. In that case, don't install the control

system to avoid damaging it.

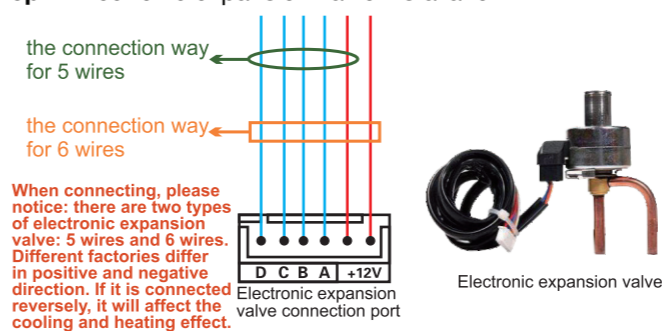
Step 2: Electronic expansion valve installation.

The way to confirm the positive direction of electronic expansion valve: When electrifying, before the compressor's running, the electronic expansion valve will reset, and it will turn off then turn on. Please connect a single electronic expansion valve, and make the coil and the valve body assembled correctly. After power on, blow air with your mouth. If you feel more and more difficult when blowing but it is still ventilated, which means the connection of electronic expansion valve is correct. If you can blow smoothly in the beginning but it is blocked finally, which means the connection direction is reversed. You need to adjust the line order of ABCD. (exchange the A line with D line, and exchange B line and C line).

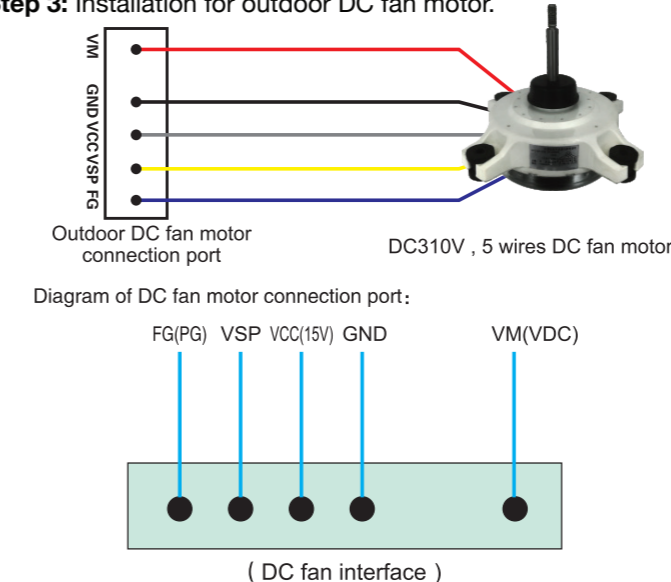
Step 3: Installation for outdoor DC fan motor.

Notice:
(1) This port is for the 5 wires DC fan motor, make sure the line order is correct.
(2) If the outdoor fan motor is not DC, then it is AC, since they can not coexist. If the outdoor fan motor is AC, then you need to use the indoor board to control it.

Step 4: Install all the components very well then start power-on test. After power on, if the green LED light is on, which means DC inverter selected. If the green LED light flickers, which means AC inverter selected.

⚠️ Stabilize MCRC-002 original heat sink with the original one through silicone grease to ensure better heat dissipation. And also use two screws to tighten up the two heat sinks.

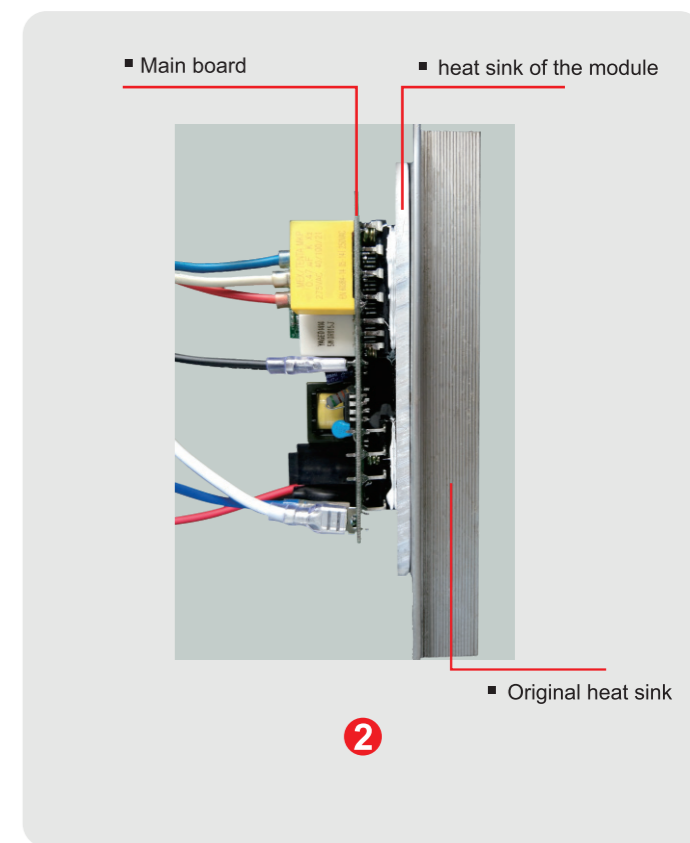
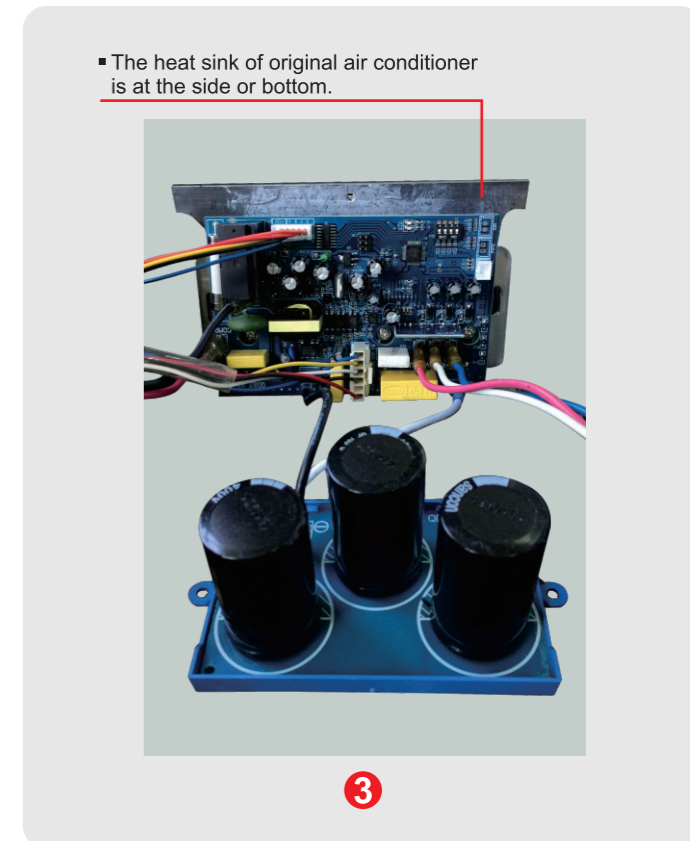
3) Graphic reference for installation:

B. Fault guide for outdoor units

• DC inverter outdoor unit trouble code meaning:

Red LED Light Flashing Frequency	Trouble Explanation
Once	DC bus over voltage and undervoltage
Twice	Over Current Protection
3 Times	1PM Overcurrent Protection
4 Times	Over Exhaust Temperature
5 Times	Compressor Rotor Out-of step Trouble

Note: when the outdoor unit shut-down alarm blows, identify trouble reasons and restart after power off to end the alarm.

• AC inverter outdoor unit fault code meaning:

Red LED Light Flashing Frequency	Trouble Explanation
Once	DC bus over voltage and undervoltage
Twice	Over Current Protection
3 Times	IPM Overcurrent Protection
4 Times	Over Exhaust Temperature

C. Technical parameters

Application Scope	Split Air Conditioner
Once	DC bus over voltage and undervoltage
Twice	Over Current Protection
3 Times	1PM Overcurrent Protection
4 Times	Over Exhaust Temperature
5 Times	Compressor Rotor Out-of step Trouble

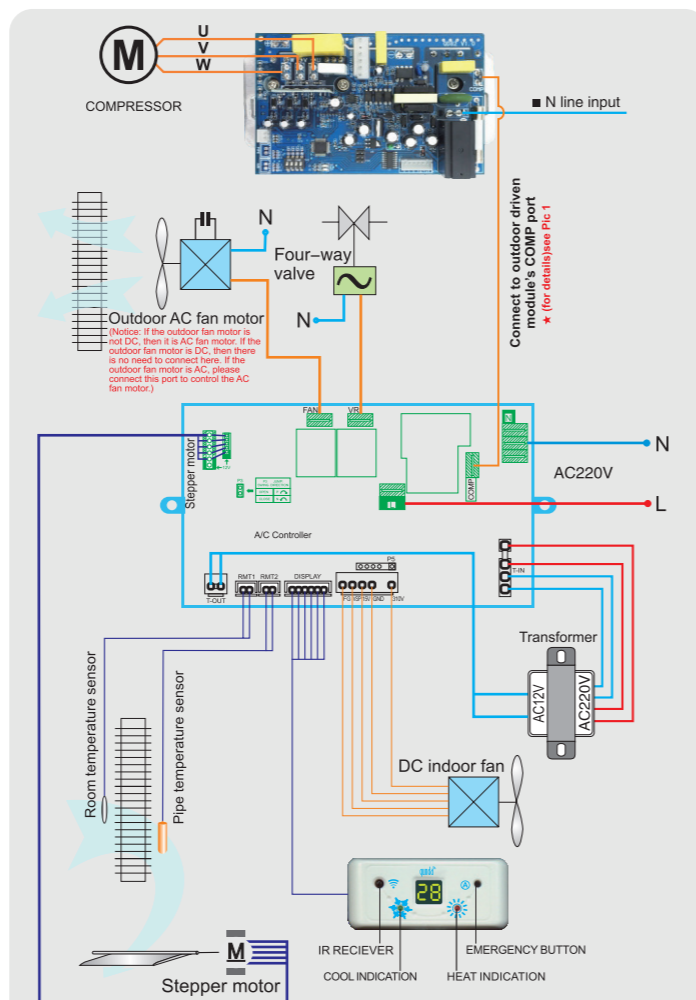
Attention:

1. Ensure there is no strong light in front of IR receiver.
2. The common pin of stepper motor output socket is 12V. The stepper motor common pin has to be inserted into one common pin of the stepper motor output socket. It will control the positive and negative rotation of the stepper motor by using and not using short circuit jumper for P3.

P3 jumper: the swing direction for stepper motor

- P3: open circuit the stepper motor rotates positively
- P3: short circuit the stepper motor rotates reversely

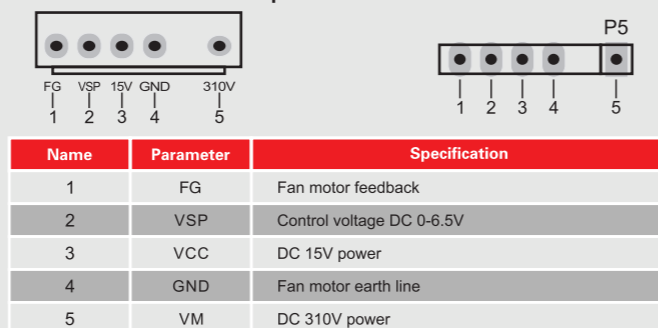
DC fan motor connection port rule

4
B. Indoor Unit Fault Code Meaning

Trouble Display (In Display Panel)	Trouble Explanation
E1	Room Temperature Sensor trouble
E2	Indoor Pipe Temperature Sensor Trouble

3
C. Indoor Unit Display Panel Instruction
1) MODE DISPLAY:
AUTO MODE: Temperature directories display **AU**
COOL MODE: Cool indicator light on, temperature directories display setting temperature and room temperature, when setting it display setting temperature that by remote, and then display room temperature.

DRY MODE: Temperature directory displays **dR**.

VENTILATION MODE: Temperature directory displays **FR**.

HEAT MODE: Heat indicator light on, temperature directory will display setting temperature and room temperature. When defrosting, temperature area displays **dF**, indicate that air conditioner is in defrosting state.

SLEEP: When in sleep mode, the luminance will be dark, make people have a good rest, setting temperature adjusts automatically and air conditioner shuts down after 8 hours.

TIMER ON: Temperature area displays **ON** and flashes, it means air conditioner is in timer on mode.

TIMER OFF: Temperature directory displays the current mode or temperature and flashes, it means air conditioner is in timer off mode.

2) REMARKS
IR RECEIVER: To receive the instruction from remote.
EMERGENCY BUTTON: Without remote, pressing this button can start air-conditioner. Press it to turn into cool mode, setting temperature will be 26°C, fan speed and direction will be automatical. Press again, it will turn into heat mode, setting temperature is 20°C, fan speed and direction will be automatical. Press again to turn off the air-conditioner. Circulating operation.

3) COMPRESSOR INSTRUCTION

In heat or cool mode, when indicator light of heat and cool flashes, it means air-conditioner reaches the setting temperature, or compressor in 3 minutes protection state, compressor shut down now, when the indicator light on, it means compressor is on.

D. Indoor Unit Remote Manual
1) ON/OFF key: press to turn on/ off the A/C.

2) TEMP (temperature setting key): It can set the temperature from 16°C to 30°C. The key would not work under the auto or dry mode.

3) MODE KEY: Working modes conversion (auto, cooling, dry, ventilation, heating). In the auto mode, the A/C would come to the heating mode when the room temperature is under 21°C; when the room temperature is higher than 27°C, the A/C would come to the cooling mode. The setting temperature is 24°C.

4) FAN KEY: Fan speeds conversion. In the dry mode, the indoor fan is low speed and works automatically: it is the high speed when the temperature gap between the setting temperature and the room temperature is more than 4°C; 2-3°C is the middle speed; 2°C is the low speed. The wind speed would convert in every minute.

5) 26°C KEY: 26°C key would set the A/C in the cooling mode and provide you the environmental-friendly and comfortable temperature.

6) SWING KEY: Press to set the vane to swing or not.

7) F. HEAT KEY: 20°C key would set the A/C in the heating mode and provide you the environmental-friendly and comfortable temperature.

8) SLEEP: Press to set the sleep mode. In the sleep mode, the fan coil would turn off automatically in 8 hours.

9) TIMER: press for timer on/off or cancelling the timer.

10) TIME+ \ TIME-: the time setting range from 1 to 16 hours.

11) RESET: press to reset the remote control.

Packing Components

Item	Number	Unit
Universal Indoor Board	1	Piece
Indoor Unit Sensor	2	Pieces
Transformer	1	Piece
Display Panel	1	Piece
Outdoor Inverter Board	1	Piece
Compressor Exhaust Temperature Sensor	1	Piece
Electrolytic Capacitor Board	1	Piece
Remote Control	1	Piece
User's Manual	1	Piece
Packaged parts	1	Piece

Indoor Unit Instructions
A) Indoor Unit Wire Diagram And Installation Instruction

1) Universal indoor board control the compressor driven board, four-way valve, and outdoor AC fan motor.