

DTP-3

Digital Three Phase

Motor Protector / Power Monitor Installation and Operation Instructions



KEY FEATURES

- ✓ Digital voltmeter displays instantaneous line voltage for all 3 phase pairs
- ✓ Contactor load side monitor checks for contactor closure
- ✓ One button contactor load side voltage measurement
- ✓ Automatic voltage tester adjusts from 160 to 600 volts
- ✓ Adjustable response timer (0.1 to 20 sec.) prevents nuisance tripping
- ✓ Adjustable delay on break (DOB) timer (0 to 720 sec.) prevents rapid re-starts
- ✓ Adjustable timer (0 to 30 sec.) allows sequencing of multiple units
- ✓ Off, Auto, On settings for operation with or without control inputs
- ✓ Selectable contactor test. Opens contactor if any one of 3 circuits fail
- ✓ Digital display makes for easy viewing and operation
- ✓ Fault memory records up to 25 fault causes

SPECIFICATIONS

✓ Voltmeter:	70 to 650 Volts: simultaneous display of AB BC CA voltages
✓ Accuracy	+ / - 2% of indicated average voltage
✓ Tolerance Limits:	6 to 18%
✓ Imbalance:	2 to 25%
✓ Response Timer:	0.1 to 20 seconds
✓ DOB Timer:	0 to 720 seconds
✓ Delay Timer:	0 to 30 seconds
✓ Contactor Test	Contactor opens and remains locked out if voltage difference is 5 volt for any phase pair.
✓ Output Relay:	10 Amps, 250 VAC resistive, single-pole/double-throw
✓ Control Input:	18 to 250 VAC with anticipator load for 24 volt thermostats

Factory Settings:	208 volts	6% imbalance	12% tolerance
	30 second DOB lockout	2 second response	0 second delay
	Control: auto	Contactor test: off	

OVERVIEW

The DTP-3 Line Voltage Monitor provides continuous monitoring of the power and control signals used to operate any three phase load. Protected devices can include motors, pumps, fans, compressors and other devices.

The DTP-3 protects these devices by keeping a constant watch over the supplied voltage, and when the voltage goes outside of a voltage and tolerance that you select, the DTP-3 opens its control relay.

The time required to respond to the out-of-tolerance conditions is user adjustable and may be set for shorter times for sensitive devices or longer times to help eliminate nuisance tripping.

Each of the three line voltage pairs are

checked for voltage level and phase to phase balance. Further testing of the system includes contactor-load-side monitoring. When enabled, the load side monitor checks the contactor for closure. If the contactor load side voltage does not match the line side voltage to 5 volts within 0.5 seconds after the control relay closes, the control relay is opened and remains locked out until power to the DTP-3 is cycled off and on.

Additionally, phase rotation is tested. If the rotation is reversed, operation of the output relay is inhibited.

If any of the limits that you set are exceeded, the response timer will begin counting. You also have the flexibility to set the response timer -- a short time may be desired for a quick response or a long time may be desired to avoid nuisance tripping. If the voltage

remains outside the tolerance after the response time has elapsed, the DTP-3 will turn off its output relay and protect your device.

When the DTP-3's relay opens, the delay timer starts. This timer keeps track of the time since the output was turned off and prevents the protected equipment from restarting too soon. The delay is also user adjustable. It is particularly useful for the protection of

or compressor contactor.

The DTP-3 should be mounted on a metal surface with four #8 sheet metal screws. Mounting on a metal surface helps dissipate heat and shield the DTP-3 from nearby equipment radiation.

WIRING

If the voltage being monitored is tapped from a high current source, branch circuit protection

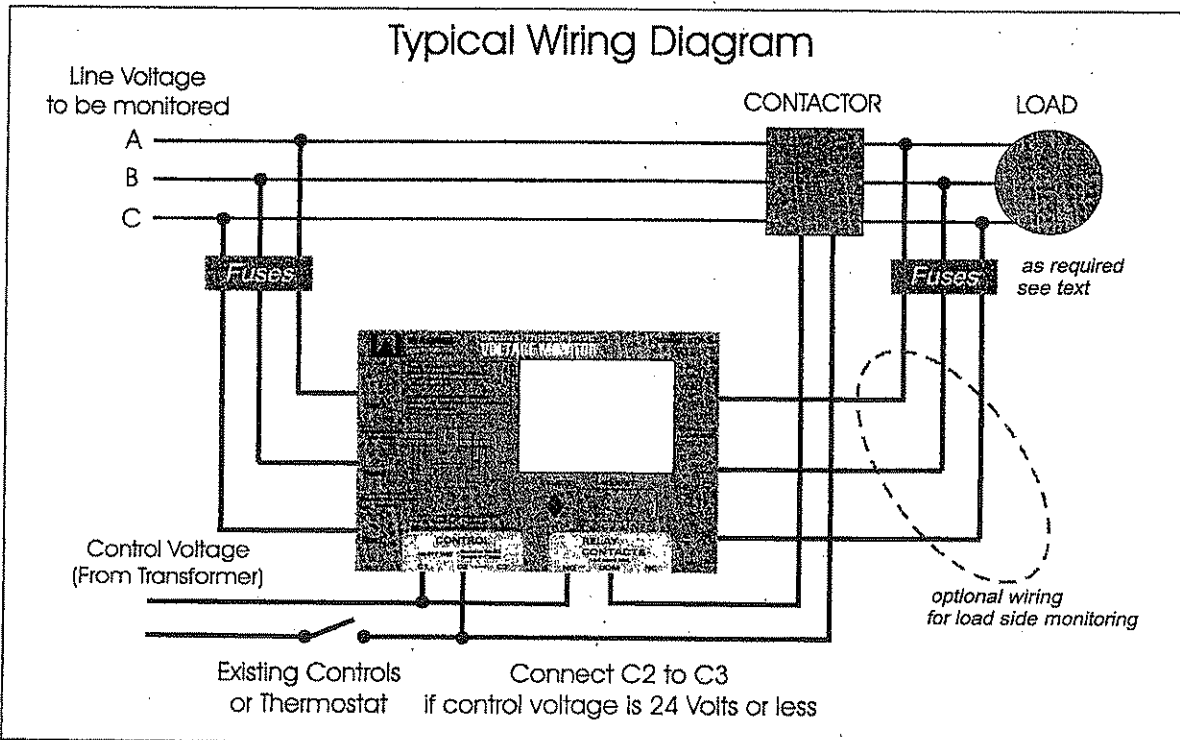

ALWAYS USE EXTREME CAUTION WHEN INSTALLING OR ADJUSTING EQUIPMENT UTILIZING HAZARDOUS VOLTAGES !

compressors, where an attempted rapid restart can cause a stalled condition and motor burnout.

DISCONNECT ALL POWER BEFORE STARTING THE INSTALLATION OF THE DTP-3

INSTALLATION

Installation of the DTP-3 is simple and straight forward.

MOUNTING

Select a cool, dry location for the mounting of the DTP-3. Keep in mind that the front of the unit has the operator controls and the digital display. The front of the DTP-3 should be clear of obstructions and allow easy access to the control buttons. A suitable location may be in the control enclosure, near the motor starter

(fuse or circuit breaker as described in the National Electric Code) should be provided. Since the current drawn by the DTP-3 is a fraction of an Amp, the branch protection can be selected for the wire type used. Typically, fuses rated at 1 Amp will provide the required protection. If the load side monitor option is utilized, it's wiring must also be current limited.

PINOUT DESCRIPTION

L1, L2 and L3

Connect the voltage being monitored to the DTP-3's L1, L2, and L3 terminals. This voltage will also power the DTP-3 and should come from a source such as the line side of the contactor being controlled.

T1, T2 and T3

If your application requires contactor load side monitoring, you should connect the contactor

load side to the DTP-3's T1, T2 and T3 terminals. Note that the load side monitoring should also include the required fusing to meet the branch circuit protection requirements of the National Electric Code or locale equivalent. If installed, the contactor fault option should be set to "ON".

NC, NO and COM

These terminals connect to the relay output. The relay closes when the line voltage is within the selected tolerance, the control voltage is on and the delay timer has expired. Typically you would connect the COM and NO terminals in series with the control circuit, motor starter or contactor coil.

C1, C2 and C3

Connect a control voltage to C1 and C2. The DTP-3 responds to voltage between 18 and 250 Volts and draws only a fraction of an Amp. An internal anticipator load is provided by connecting C2 to C3 to allow the use of a 24 Volt thermostat. Be sure to only connect C3 for 24 Volt or lower operation.

SETUP

The DTP-3 may be setup at a shop or other location prior to installation by simply applying power to any of the three line-side phase pairs. The DTP-3 will power up on single phase power and allow the setting of user parameters prior to installation in a three phase system.

After completing the installation (or for stand-alone setup), apply power to the DTP-3. The DTP-3 display will show a brief display test followed by the firmware revision number. The DTP-3 will then indicate the remaining time on any active timers. If the timers are expired the incoming line voltage will be displayed. The OVERVOLTAGE, UNDERVOLTAGE, PHASE LOSS and/or the PHASE REVERSAL indicators may also be visible depending on the factory settings versus your incoming line voltage.

During any point in the DTP-3's operation, you may read the incoming voltage by pressing the SELECT button to return to the AB BC CA voltmeter. (Normal Display)

THE DISPLAY

The display normally shows the AB BC and CA line voltages.

If the unit is waiting on a timer, that timer will be displayed. The timer display may be switched off by pressing SELECT. The LCD will then

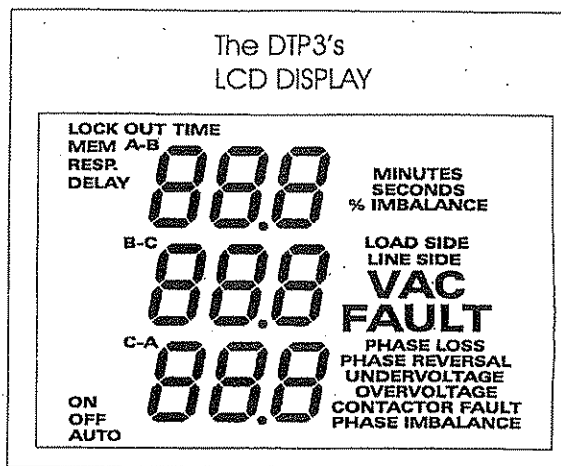

display the normal AB BC CA voltage pairs.

Pressing the SELECT button once shows the contactor load side voltages. (if the load side option is connected) The display automatically returns to the display of line side voltage after a few seconds.

Press the Select button to step through the parameters. As you step through the parameters, the selected parameter will flash. Use the up and down arrow keys to adjust to the desired operating value.

- Line side voltage*
- Load side voltage*
- Voltage set point.*
- Under/over voltage tolerance in %*
- Imbalance voltage tolerance in %*
- Lockout time in seconds*
- Delay time in seconds*
- Response time in seconds*
- Control mode*
- Contactor fault monitor*
- Fault Memory Display*

Parameters adjustment (in order of display)
Active display of Line Voltage (this is the default normal display)

Active display of Load Side Voltage (if connected)

Voltage Set Point
(VAC Flashes) The value may be adjusted by pressing the up and down arrows. This may be set to the normal operating voltage of the device being protected in one volt increments.

Under/over Voltage Tolerance in %
(UNDERVOLTAGE/OVERVOLTAGE flashes)
The value may be adjusted by pressing the up and down arrows.

Imbalance Voltage Tolerance in %
(% IMBALANCE flashes). The value may be adjusted by pressing the up and down arrows.

Lockout Time in seconds
(SECONDS flashes). The value may be adjusted by pressing the up and down arrows. (This is the delay on break timer value)

Delay time in seconds
(DELAY SECONDS flashes). The value may be adjusted by pressing the up and down arrows. This is the Random Start Delay value. (This is a delay on make timer)

Response time in seconds and tenths of seconds (RESP. SECONDS flashes) The value may be adjusted by pressing the up and down arrows. This is the time that a fault is allowed before shutdown occurs.

Control mode
(ON OFF AUTO flashes) The value may be adjusted to OFF (load will not turn on), ON (load will turn on whenever there are no faults and the timers are finished) and AUTO (load will turn on when there is a control input).

Contactors fault monitor mode
(CONTACTOR FAULT flashes) This option allows you to monitor the contactor and lock it out if the line voltage and load side varies by more than 5 volts. Pressing the up or down arrows selects off (default) or on. The load side of the contactor must be connected to the load terminals of the DTP-3 to use this option.

Display of fault memories
(MEM flashes) Pressing up or down displays the past fault conditions that took your unit off line. The first 25 faults are recorded. The top number displayed represents the fault memory. The middle number represents the total number of faults that have occurred since the fault memory was cleared.

To clear the memory, press and hold the up and down keys until the display is cleared.

Notes

If you press SELECT and do not change a parameter by pressing the up or down arrow keys, the DTP-3 automatically returns to displaying the line voltage in a few seconds.

The new settings are saved in permanent memory when the display returns to displaying the line voltage. The new settings may be verified by pressing the select button to sequence through the various parameters.

To prevent tripping on a 1 volt change, the DTP-3 automatically calculates cut-in voltages for return from undervoltage conditions. The cut-out voltage is always based on the user voltage and tolerance settings, while the cut-in voltage is 3% closer to the nominal voltage setting. This quality is sometimes referred to as hysteresis. This is to help reduce oscillation that may occur on weak power distribution systems. When the load is switched off due to undervoltage, the line voltage will increase. Without the hysteresis, the monitor would switch the load back on, the line voltage would again drop, and cause a continuous on-off-on cycling.

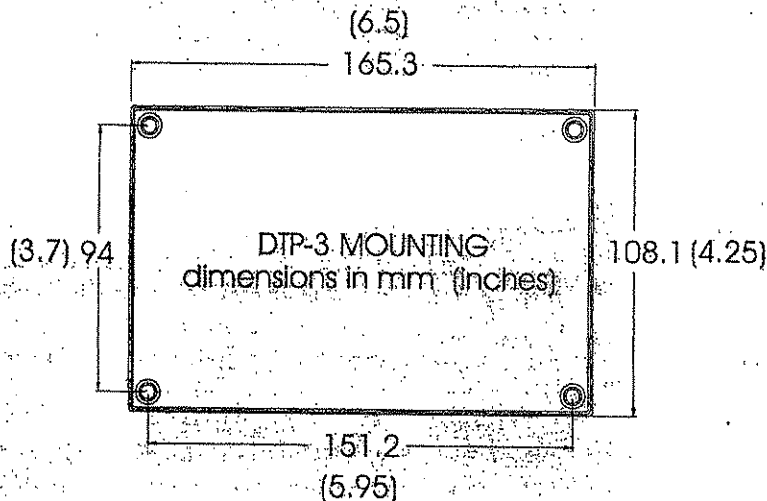

Product of DiversiTech Corp.
www.diversitech.com
Designed in U.S.A.
assembled in China